



**SUPERIOR**  
MANUFACTURING

# ***PADDING BUCKETS***

SBP-15 | SBP-25





PADDING BUCKETS

**SBP-15/25**



SCREEN VOLUME

1.5 yd<sup>3</sup> / 2.5 yd<sup>3</sup>



WEIGHT

5,622 lb / 7,716 lb



SUPERIOR PADDING BUCKETS

## ***The Perfect Tool for Tie-in Jobs and Small Jobs***

Easily attached to an excavator, Superior's padding bucket features:

- Adjustable for screened material size
- Double chain transmission
- Two hydraulic motors
- 4 screen rollers with HARDOX steel type
- Bracket support for excavator upon request

Call **888.997.3687** now to get yours!





## SBP-15

### Specifications

Screening volume	1.5 yd <sup>3</sup> (1.15 m <sup>3</sup> )
Rotor sizes	0.7 / 1 / 1½ / 2 in (18/25/38/50 mm)
Weight	5,622 lb (2,550 kg)
Recommended excavator	Cat 320 or equivalent

### Dimensions

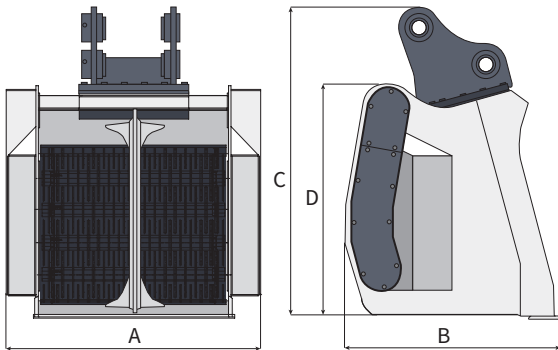

A	5.2' (1.59 m)
B	4.4' (1.34 m)
C	6.4' (1.96 m)
D	4.8' (1.47 m)

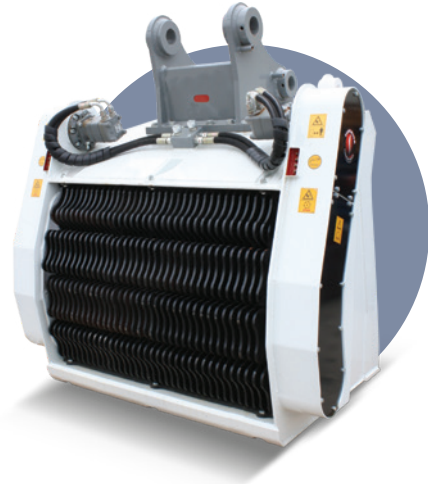

## SBP-25

### Specifications

Screening volume	2.5 yd <sup>3</sup> (1.9 m <sup>3</sup> )
Rotor sizes	1 / 1½ / 2 in (25/38/50 mm)
Weight	7,716 lb (3,500 kg)
Recommended excavator	Cat 330 or equivalent

### Dimensions

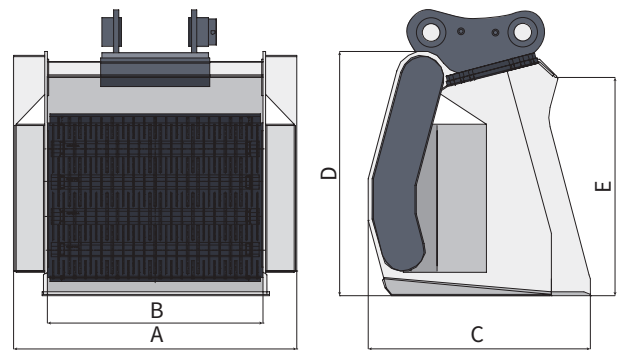

A	6' (1.82 m)
B	4.6' (1.39 m)
C	4.7' (1.43 m)
D	5.2' (1.58 m)
E	4.6' (1.41 m)



Padding Machines



Pipelayers

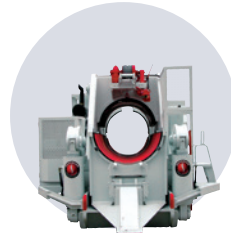

Pipe Benders

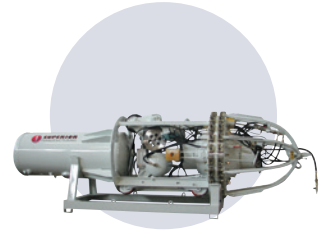

Pipeline Accessories



Crawler Carriers



Hydraulic Kits

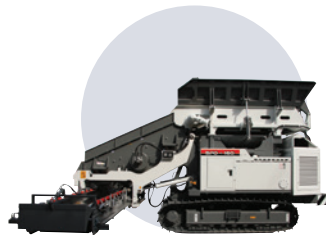

Top-Loading Padders

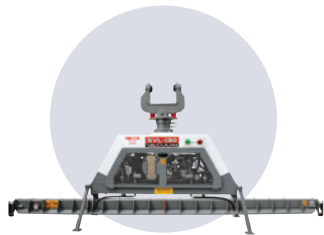

Vacuum Lifts



2200 Post Oak Blvd., Ste. 1400  
Houston, TX 77056  
Main 281.457.4400  
U.S. Toll Free 800.383.2666  
sales@superiormftg.com  
[www.superiormftg.com](http://www.superiormftg.com)

**U.S.** +1.281.457.4400  
**Canada** +1.281.457.4400  
**Mexico & Latin America** +54.911.5049.8121  
**Brazil** +54.911.4083.1274  
**Europe** +49.0.151.226.52385  
**India** +91.11.414.59230  
**Africa** +49.0.170.583.4021  
**Australia** +61.0.488.661.985  
**Middle East & Asian Pacific** +61.0.488.661.985