





MAX PRESSURE
4,640 psi



WEIGHT
149,914 lb



HORSEPOWER
225 HP

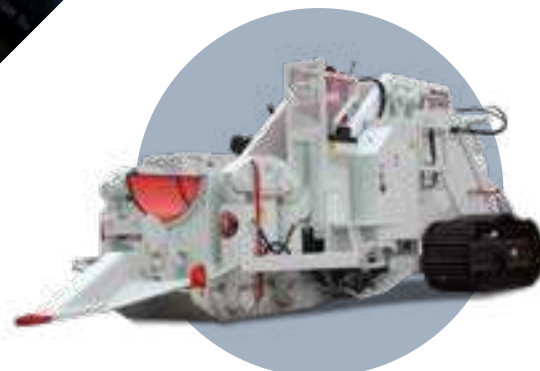

The SPB 36-48

The pipe bending machine SPB 36-48 is one of the best-selling and more frequently tested machines of the SUPERIOR fleet. The long undercarriage pitch prevents the pressure exercised by the machine on the ground from increasing and keeps it at regular levels.

Specifications

Engine

Model	Caterpillar C-6.6 ACERT
Net flywheel power (DIN 6271)	225 HP (168 kW)
Governed speed	1,900 rpm
Displacement	6.6 L
Compression ratio	16:1
Engine bore	105 mm - 127 mm
Number of cylinders	6

Hydraulic Pump

Type	Axial piston, load-sensing pump, with tilted plate and constant power control
Maximum flow rate	108 gpm (410 L/min)
Maximum constant pressure	127 gpm (483 L/min)
Maximum peak pressure	320 bar

Hydraulic Winch

Type	2.280.0019
Maximum pull at first layer	33,070 lb (15,000 kg)
Hydraulic motor	Orbital DANFOSS
Frame	Aluminum allow + ductile cast iron
Reduction gear	With worm screw, irreversible
Neutral	Manual
Maximum operating pressure	2,175 p.s.i. (150 bar)
Maximum feed flow rate	42 gpm (160 L/min)
Speed at first layer	16 ft/min (4,85 m/min)
Recommended cable diameter	3/4 inch (Ø 19 mm)
Wire rope type	6 strands with textile core
	R=2,160 N/mm2 min. breaking load guaranteed 30,000 kg

Control Valve

Brand	Rexroth
Type	Load-sensing with proportional control (LUDV)
Spools	N.6

Hydraulic Oil Tank

Type	Metal work with filter
Capacity	121 US gal (460 L)
Cartridge type	Parker

Fuel Tank

Type	Metal work with filter
Capacity	76 US gal (290 L)

Spools

Spool 1: Out-board and in-board cylinders, clamp	
Maximum flow	84.5 gpm (320 L/min)
Pressure	4,641 p.s.i. (320 bar)

Spool 2: Out-board and in-board cylinders, clamp

Maximum flow	84.5 gpm (320 L/min)
Pressure	2,175 - 3,190 p.s.i. (150 - 220 ² bar)

Spool 3: Wedge cylinder

Maximum flow	84.5 gpm (320 L/min)
Pressure	2,175-3,190 p.s.i. (150-220 ² bar)

Spool 4: Winch

Maximum flow	42.2 gpm (160 L/min)
Pressure	1,990 p.s.i. (140 bar)

Spool 5: Auxiliary control 1

Maximum flow	42.2 gpm (160 L/min)
Pressure	1,740 p.s.i. (120 ² bar)

Spool 6: Auxiliary control 2

Maximum flow	42.2 gpm (160 L/min)
Pressure	1,740 p.s.i. (120 ² bar)



Bending Data

Pipe Size	Maximum Wall Thickness By Grade (inches)							Recommended Bend		
	X52	X56	X60	X65	X70	X80	X100	Degree per Arc Foot	Radius Feet	Max Degree Per 40 Feet
36"	2	2	2	2	2	2	1-3/4	0.50	115	12.75
38"	2	2	2	2	2	2	1-9/16	0.50	115	12.75
40"	2	2	2	2	2	1-3/4	1-3/8	0.50	115	12.75
42"	2	2	2	2	1-13/16	1-9/16	1-3/16	0.50	115	12.75
44"	2	2	1-15/16	1-3/4	1-5/8	1-3/8	1-1/16	0.50	115	12.75
46"	2	1-7/8	1-11/16	1-9/16	1-7/16	1-1/4	1	0.50	115	12.75
48"	1-13/16	1-11/16	1-9/16	1-7/16	1-5/16	1-1/8	7/8	0.50	115	12.75

Pipe Size	Maximum Wall Thickness By Grade (mm)							Recommended Bend		
	X52	X56	X60	X65	X70	X80	X100	Degree per Arc Foot	Radius Meter	Max Degree Per 12 Meters
36" (914.4)	50.80	50.80	50.80	50.80	50.80	50.80	44.45	38.3	35.05	12.75
38" (965.2)	50.80	50.80	50.80	50.80	50.80	50.80	39.69	36.3	35.05	12.75
40" (1016)	50.80	50.80	50.80	50.80	50.80	44.45	34.93	34.5	35.05	12.75
42" (1066.8)	50.80	50.80	50.80	50.80	46.04	39.69	30.17	32.9	35.05	12.75
44" (1117.6)	50.80	50.80	49.22	44.45	41.28	34.93	26.99	31.4	35.05	12.75
46" (1168.4)	50.80	47.63	42.87	39.69	36.52	31.75	25.40	30.0	35.05	12.75
48" (1219.2)	46.04	42.87	39.69	36.52	33.34	28.58	22.23	28.8	35.05	12.75

Dimensions

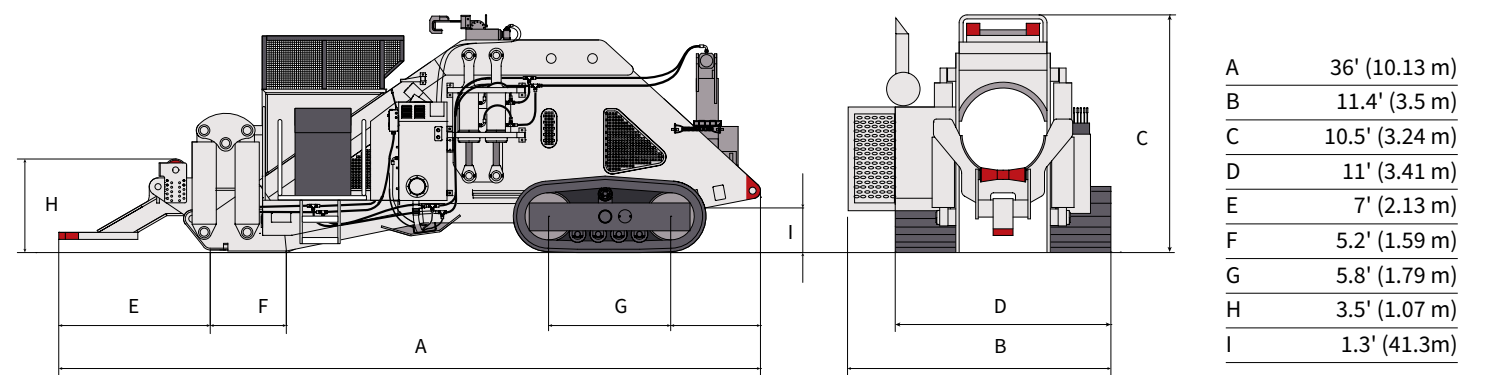

Mandrels

Model	Pipe Size	Dimensions (L X W X H)	Weight
SWH 10	10"	73 x 8 x 8" (1,850 x 203 x 203 mm)	374 lb (170 kg)
SWH 12-14	12-14"	81 x 12 x 12" (2,050 x 305 x 305 mm)	440 lb (200 kg)
SWH 16-18	16-18"	86.5 x 16 x 16" (2,200 x 407 x 407 mm)	924 lb (420 kg)
SWH 20-22	20-22"	95.5 x 20 x 20" (2,430 x 508 x 508 mm)	1,452 lb (660 kg)
SWH 24-26	24-26"	107.5 x 22 x 22" (2,730 x 559 x 559 mm)	1,760 lb (800 kg)
SWH 28	28"	107.5 x 24 x 24" (2,730 x 610 x 610 mm)	2,904 lb (1,320 kg)
SWH 30-32	30-32"	123.5 x 28 x 28" (3,140 x 711 x 711 mm)	3,795 lb (1,725 kg)
SWH 34-36	34-36"	123.5 x 31 x 31" (3,140 x 787 x 787 mm)	3,927 lb (1,785 kg)
SWH 36-38	36-38"	115 x 33 x 33" (2,920 x 838 x 838 mm)	5,390 lb (2,450 kg)
SWH 40-42	40-42"	115 x 37 x 37" (2,920 x 940 x 940 mm)	5,522 lb (2,510 kg)
SWH 42-44	42-44"	158 x 39 x 39" (4,013 x 990 x 990 mm)	8,020 lb (3,638 kg)
SWH 46-48	46-48"	158 x 43 x 43" (4,013 x 1,092 x 1,092 mm)	9,504 lb (4,320 kg)
SWH 48-50	48-50"	158 x 45 x 45" (4,013 x 1,143 x 1,143 mm)	11,030 lb (5,003 kg)
SWH 52-54	52-54"	158 x 49 x 49" (4,013 x 1,245 x 1,245 mm)	11,946 lb (5,430 kg)
SWH 56-58	56-58"	158 x 50 x 50" (4,013 x 1,270 x 1,270 mm)	13,112 lb (5,960 kg)
SWH 60-62	60-62"	158 x 54 x 54" (4,013 x 1,372 x 1,372 mm)	13,640 lb (6,200 kg)
SWH 64-66	64-66"	158 x 58 x 58" (4,013 x 1,473 x 1,473 mm)	14,828 lb (6,740 kg)

Line-up Clamps

Model	Pipe Size	Dimensions (L X W X H)	Weight
SLC 8	8"	59.5 x 7.5 x 9" (1,510 x 190 x 229 mm)	253 lb (115 kg)
SLC 10	10"	64 x 10 x 11.5" (1,625 x 254 x 292 mm)	286 lb (130 kg)
SLC 12-14	12-14"	90.5 x 12 x 13.5" (2,300 x 305 x 343 mm)	319 lb (145 kg)
SLC 16-18	16-18"	95.5 x 16 x 17.5" (2,430 x 406 x 445 mm)	418 lb (190 kg)
SLC 20-22	20-22"	105 x 18.5 x 20" (2,680 x 469 x 508 mm)	693 lb (315 kg)
SLC 24-26	24-26"	113.5 x 26 x 27.5" (2,880 x 660 x 698 mm)	935 lb (425 kg)
SLC 28	28"	113.5 x 28 x 29.5" (2,880 x 710 x 749 mm)	1,122 lb (510 kg)
SLC 30-32	30-32"	124.5 x 30 x 31.5" (3,160 x 762 x 800 mm)	1,148 lb (522 kg)
SLC 34-36	34-36"	134 x 36 x 37.5" (3,400 x 910 x 952 mm)	2,640 lb (1,200 kg)
SLC 40-42	40-42"	140 x 40 x 41.5" (3,550 x 1,016 x 1,054 mm)	3,080 lb (1,400 kg)
SLC 46-48	46-48"	151 x 45 x 46.5" (3,850 x 1,143 x 1,181 mm)	4,290 lb (1,950 kg)
SLC 50-52	50-52"	157 x 50 x 51.5" (4,000 x 1,270 x 1,308 mm)	4,620 lb (2,100 kg)
SLC 54-56	54-56"	157 x 54 x 55.5" (4,000 x 1,372 x 1,410 mm)	4,950 lb (2,250 kg)
SLC 56-60	56-60"	181 x 58 x 59.5" (4,600 x 1,473 x 1,511 mm)	5,170 lb (2,350 kg)
SLC 60-64	60-64"	181 x 62 x 63.5" (4,600 x 1,575 x 1,613 mm)	5,720 lb (2,600 kg)



Bending Sets

Bending sets are available bare or with linings to accommodate special conditions and non-standard pipe or coating. Standard bending sets will accommodate pipe manufactured to API-5L. The largest pipe size in a given pipe bending machine range requires a bending die only.

For SPB 6-20	For SPB 16-30	For SPB 22-36	For SPB 32-42	For SPB 36-48	For SPB 48-60
LBS 6/20	LBS 16/30	LBS 22/36	LBS 32/42	LBS 36/48	LBS 48/60
LBS 8/20	LBS 18/30	LBS 24/36	LBS 34/42	LBS 38/48	LBS 50/60
LBS 10/20	LBS 20/30	LBS 26/36	LBS 36/42	LBS 40/48	LBS 52/60
LBS 12/20	LBS 22/30	LBS 28/36	LBS 38/42	LBS 42/48	LBS 54/60
LBS 14/20	LBS 24/30	LBS 30/36	LBS 40/42	LBS 44/48	LBS 56/60
LBS 16/20	LBS 26/30	LBS 32/36	LBS 42/42	LBS 46/48	LBS 58/60
LBS 18/20	LBS 28/30	LBS 34/36	-	LBS 48/48	LBS 60/60
LBS 20/20	LBS 30/30	LBS 36/36	-	-	-

The first number indicates the pipe size while the second number indicates the maximum range of the bending machine where it fits. For example: an LBS 16/20 would accommodate a 16" pipe on an SPB 6-20 bender. An LBS 16/30 would also accommodate a 16" pipe but on an SPB 16-30 bender. All models are also available as bare bending sets.



Padding Machines



Pipelayers

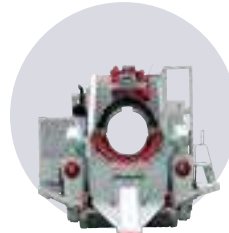

Pipe Benders

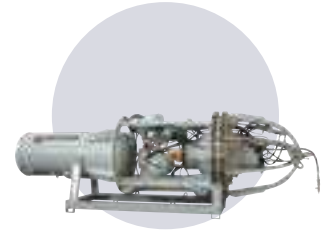

Pipeline Accessories



Crawler Carriers



Hydraulic Kits



Top-Loading Padders



Vacuum Lifts



2200 Post Oak Blvd., Ste. 1400
Houston, TX 77056
Main 281.457.4400
U.S. Toll Free 800.383.2666
sales@superiormftg.com
www.superiormftg.com

U.S. +1.281.457.4400
Canada +1.281.457.4400
Mexico & Latin America +54.911.5049.8121
Brazil +54.911.4083.1274
Europe +49.0.231.963.3073
India +91.11.414.59230
Africa +49.0.170.583.4021
Australia +61.0.400.144.432
Middle East & Asian Pacific +61.0.488.661.985